

# Ag102 Higher Back-up Voltage

The Ag102 is designed to charge a 12V Sealed Lead Acid (SLA) battery with a capacity between 1.2Ah and 7Ah. But some battery back-up applications require 24V and not 12V.

This application note shows how to connect 2 x Ag102 modules and 2 x 7Ah batteries, to increase the output voltage to 24V. Figure 1 below gives an example of how this can be achieved.

In Figure 1 the C1, ZD1, R2, RL1, Q1 and D1 are common to both Ag102 modules. RL1 coil must be 24V, but this could be a single 4 pole change-over relay or two 2 pole change-over relays.

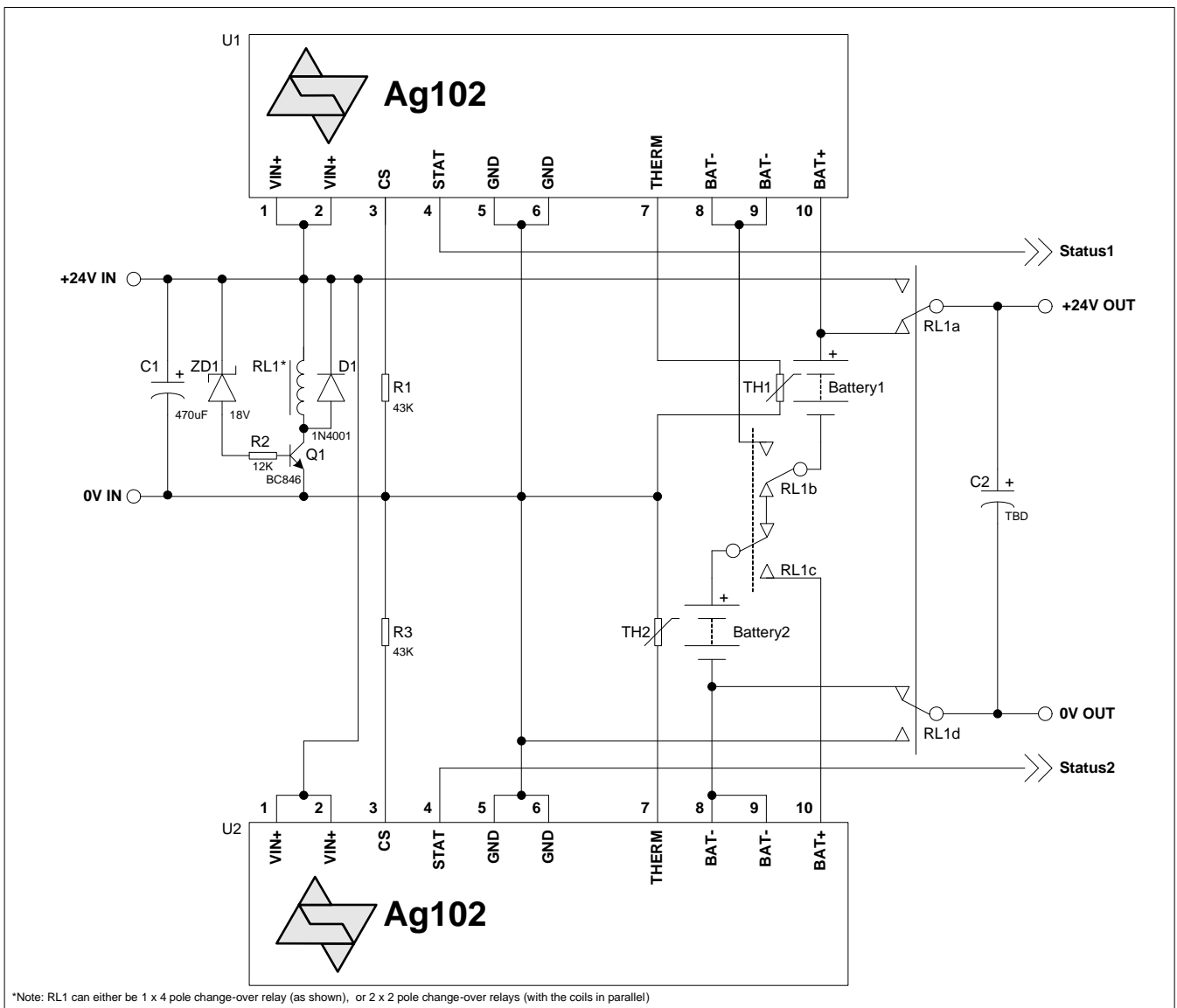

Figure 1: Series Configuration

When a 24V supply is connected to the '+24V IN' input; RL1 will activate and connect the 24V supply directly to the output (+24V OUT). At the same time it will supply power to both Ag102 modules, which will charge their respective batteries. It is important that the +24V supply has sufficient power capability to drive both Ag102 modules and the output load (when all are at maximum capacity).

If for some reason the +24V supply is lost, then RL1 will deactivate and Battery1 & Battery2 will now be connected (in series) to the output.

With the circuit shown in Figure 1, RL1 will deactivate when the voltage reaches ~19V. C2 can be fitted (if required) to prevent the output dropping to 0V before the relay fully switches over (connecting the back-up batteries). The value of C2 will be dependant on the output load requirements. But it is also very important if C2 is fitted, the contacts of RL1 can withstand the surge current required to charge C2.

When the 24V supply is connected, the status of each battery can be monitored using the Ag102 STAT output pins ('Status1' and 'Status2').