

This application note shows both correct and incorrect methods of configuring the Ag5000 outputs. The Ag5000 outputs must be connected in series or in parallel; they should not be used independently as this could have an adverse affect on Vout 2 regulation.

Parallel Configuration

Figure 1 shows the correct configuration for connecting the outputs in parallel to achieve a 12V (nominal) output. C1, C2 and C3 must be positioned as close to the Ag5000 output pins as possible. The main output is connected to Vout 1 (primary output) with Vout 2 (secondary Output) connected in parallel with it.

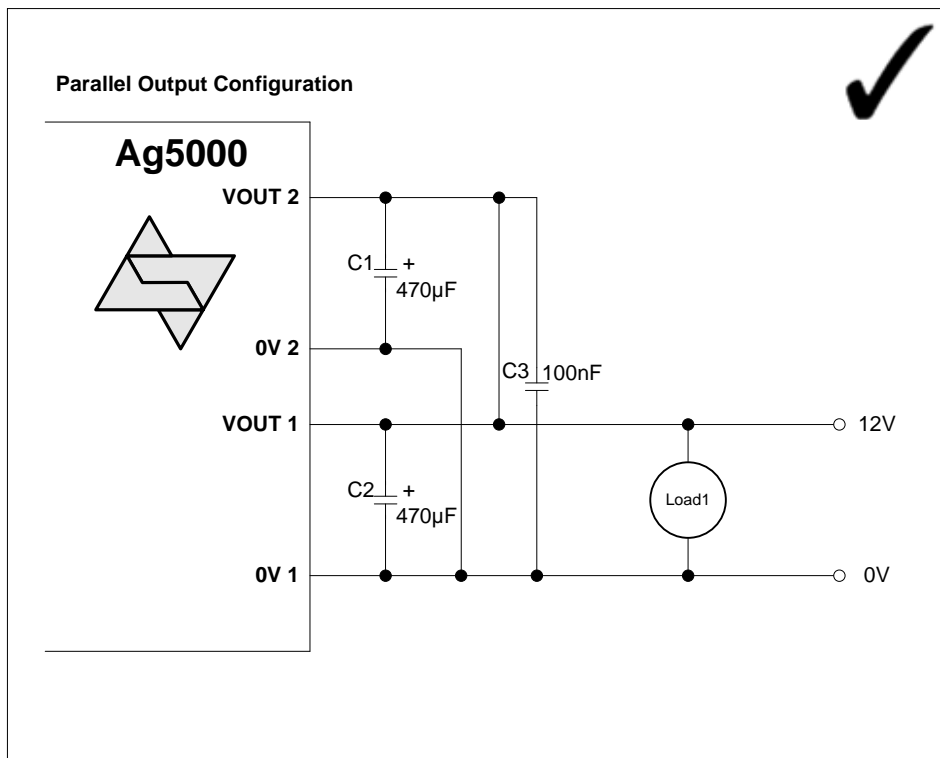

Figure 1: Correct Parallel Output Configuration

Figure 2 shows an incorrect parallel output configuration. In this case Vout 2 is shown as the primary output with Vout 1 in parallel with it and a single 1000uF capacitor is connected close to the load which is away from the output pins. This may result in low frequency oscillation at the output.

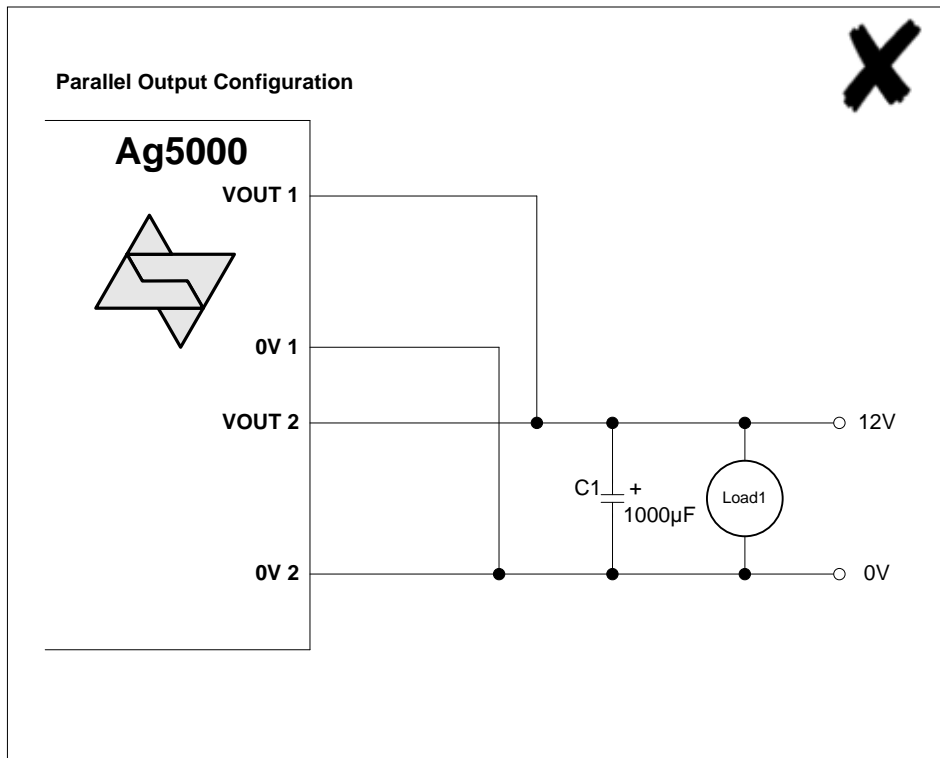

Figure 2: Incorrect Parallel Output Configuration

Series Configuration 1

Figure 3 shows the correct configuration for connecting the outputs in series to achieve a single 24V (nominal) output. C1, C2 and C3 must be positioned as close to the Ag5000 output pins as possible. Connecting C3 close to the outputs pins helps to minimise switching noise when the outputs are connected in series. The main primary output 0V 1 pin must be connected to the system 0V.

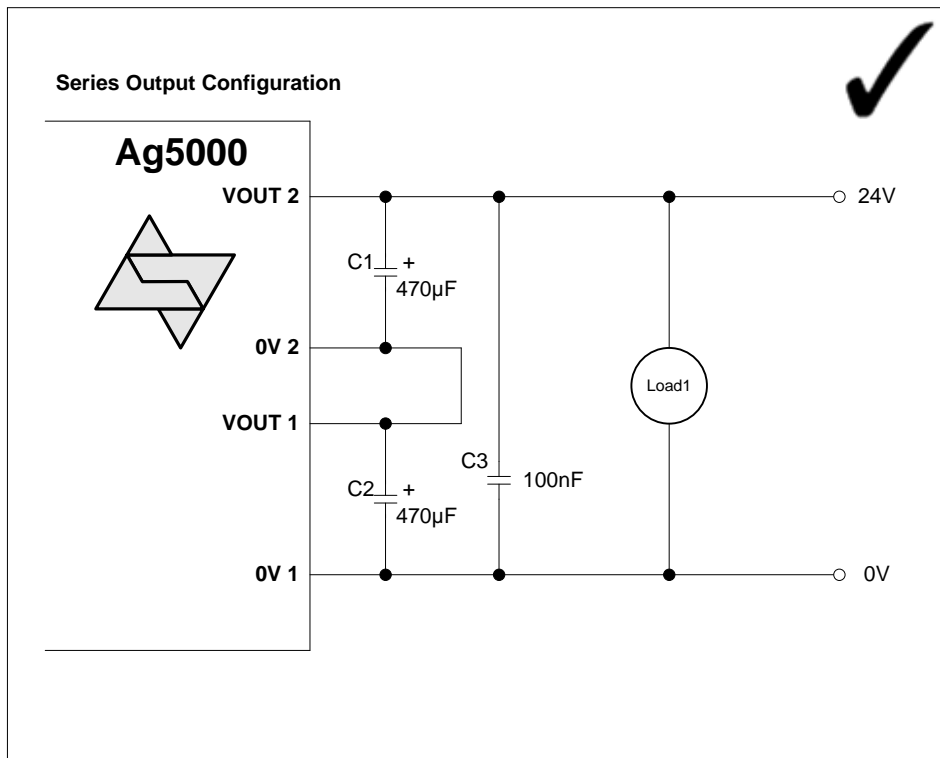

Figure 3: Correct Series Output Configuration 1

Figure 4 shows an incorrect parallel output configuration. In this case 0V 2 is connected to the system 0V and a single 1000uF capacitor is connected close to the load which is away from the output pins. This may result in low frequency oscillation at the output.

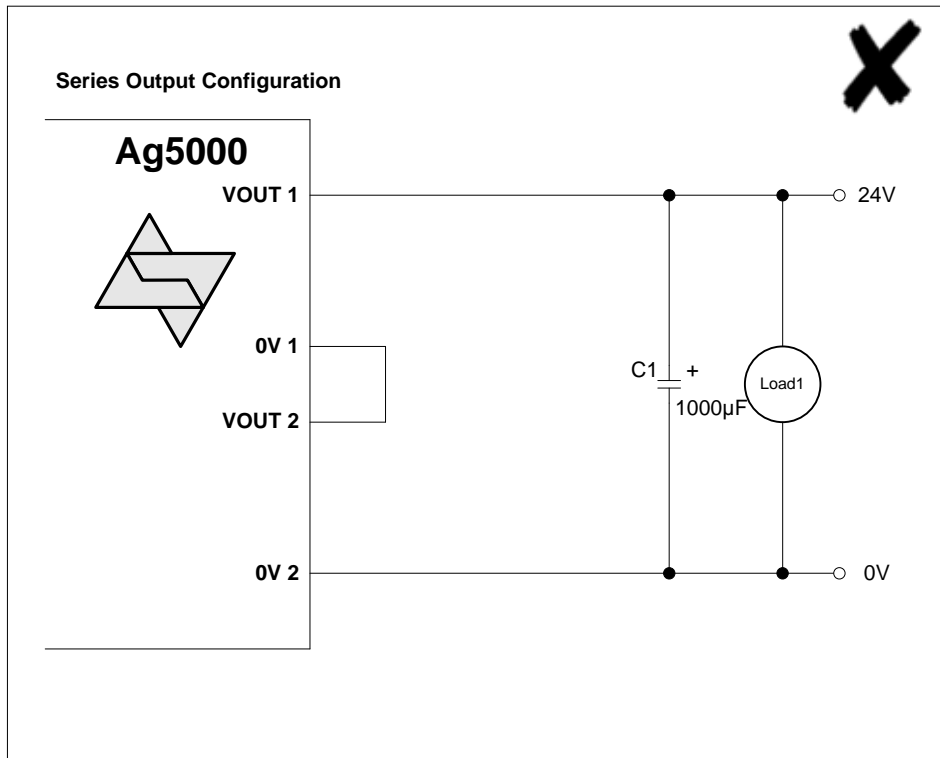

Figure 4: Incorrect Series Output Configuration 1

Series Configuration 2

Figure 5 shows the correct configuration for connecting the outputs in series to achieve both 12V and 24V (nominal) outputs. C1, C2 and C3 must be positioned as close to the Ag5000 output pins as possible. Connecting C3 close to the outputs pins helps to minimise switching noise when the outputs are connected in series. The main primary output 0V 1 pin must be connected to the system 0V.

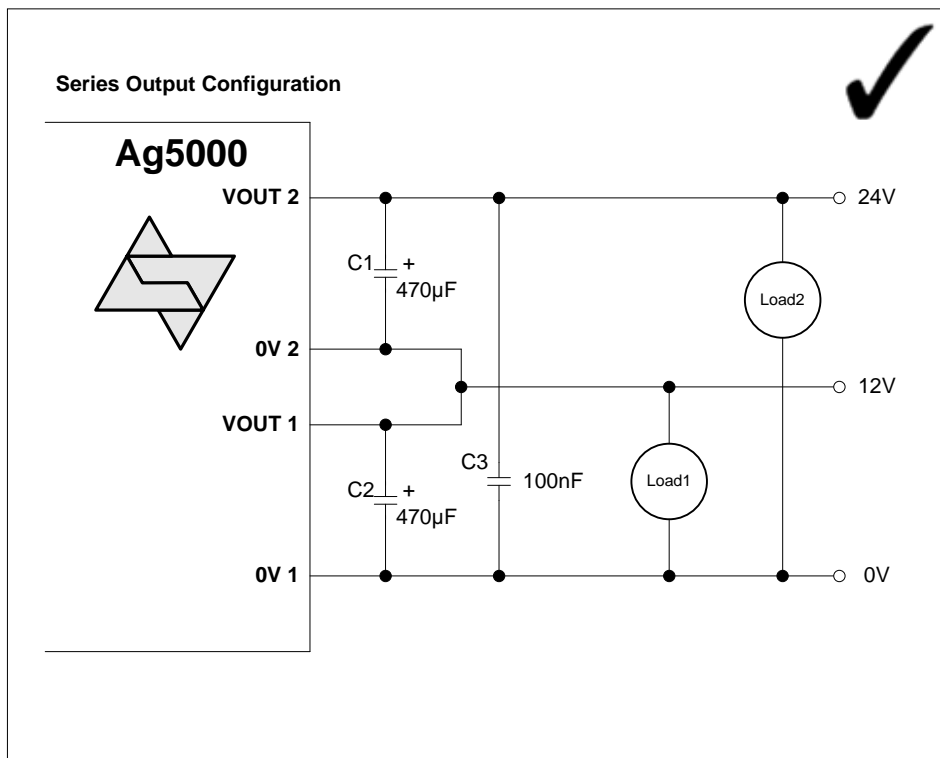

Figure 5: Correct Series Output Configuration 2

Figure 6 shows an incorrect parallel output configuration. In this case C1 and C2 are away from the output pins and C3 is not fitted. By connecting 0V 2 to the system 0V, if Load2 is below 200mA changes to Load1 will affect the output regulation of both rails.

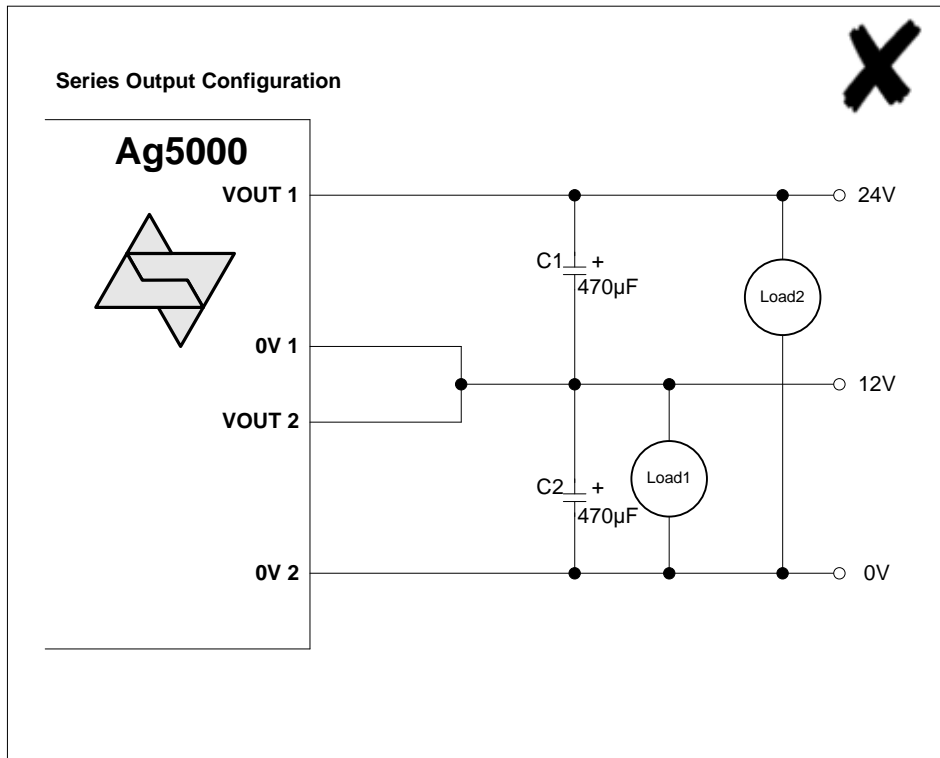

Figure 6: Incorrect Series Output Configuration 2

Series Configuration 3

Figure 7 shows the correct configuration for connecting the outputs in series to achieve both +12V and -12V (nominal) outputs. C1, C2 and C3 must be positioned as close to the Ag5000 output pins as possible. Connecting C3 close to the outputs pins helps to minimise switching noise when the outputs are connected in series. The main primary output 0V 1 pin must be connected to the system 0V.

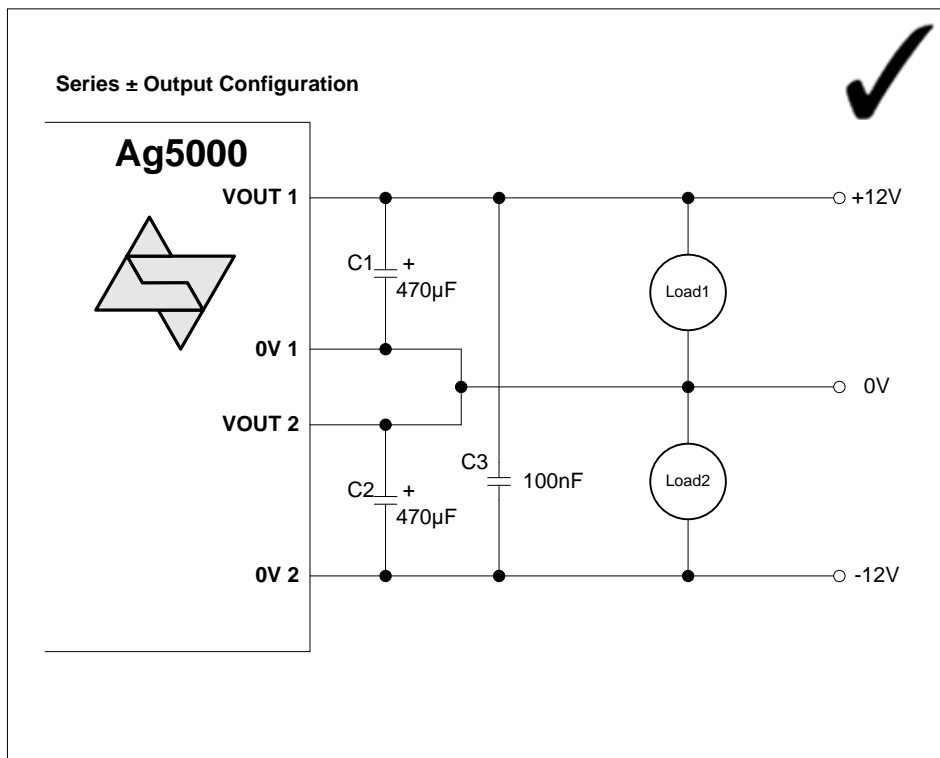

Figure 7: Correct Series Output Configuration 3

* Load1 must always be $\geq 200\text{mA}$.

Figure 8 shows an incorrect parallel output configuration. In this case C1 and C2 are away from the output pins and C3 is not fitted. By connecting 0V 2 to the system 0V, if Load2 is below 200mA changes to Load1 will affect the output regulation of both rails.

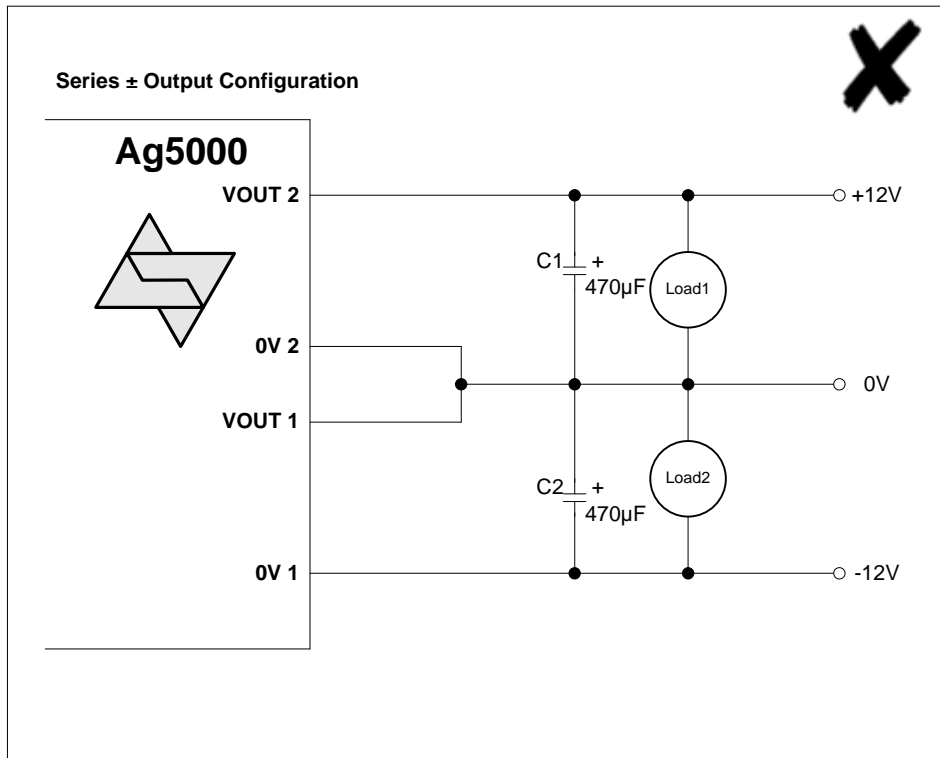
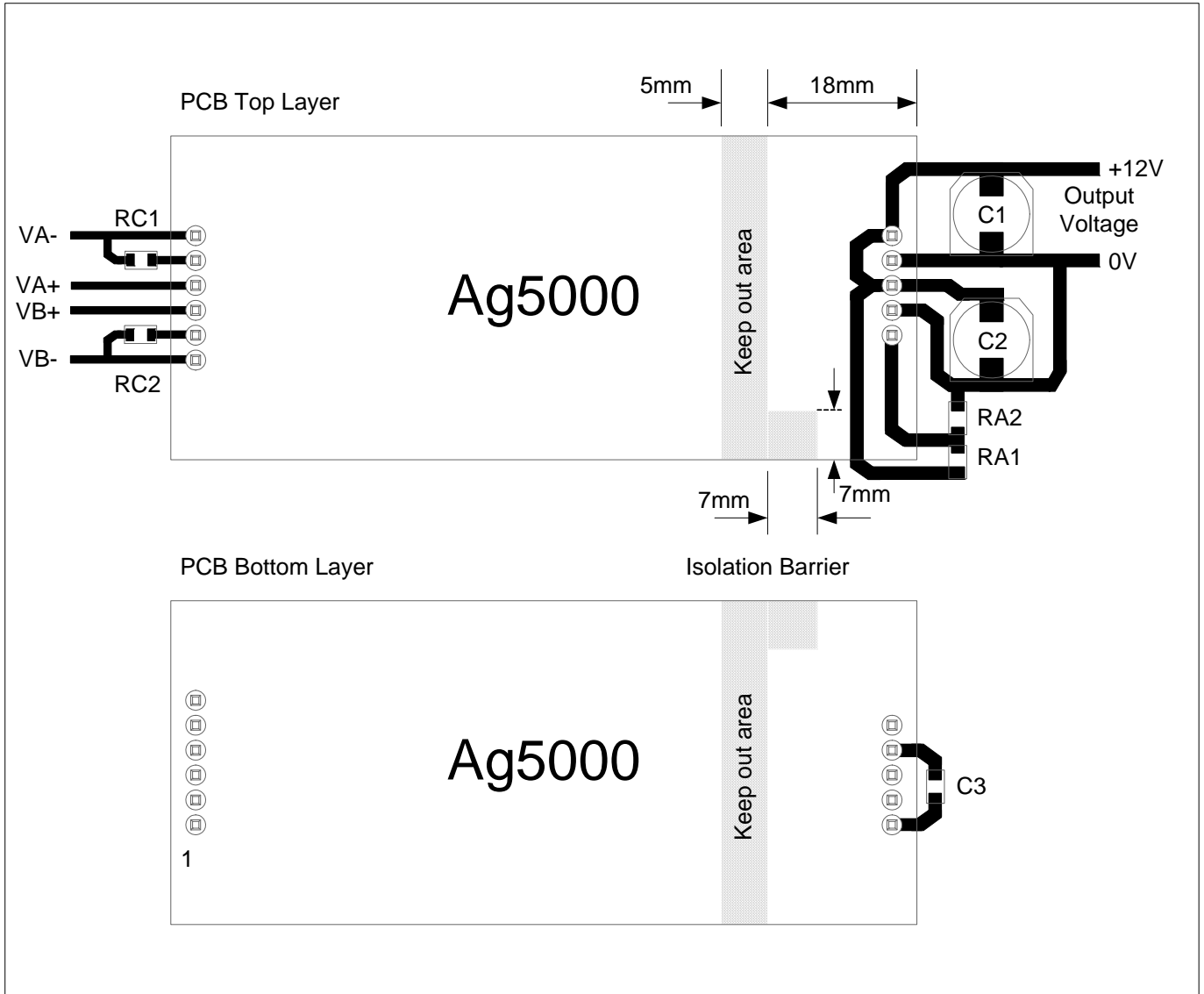

Figure 8: Incorrect Series Output Configuration 3

Ag5000 Output Configurations

Example PCB Layouts

Parallel Configuration



Ag5000 Output Configurations



Series Configuration 1

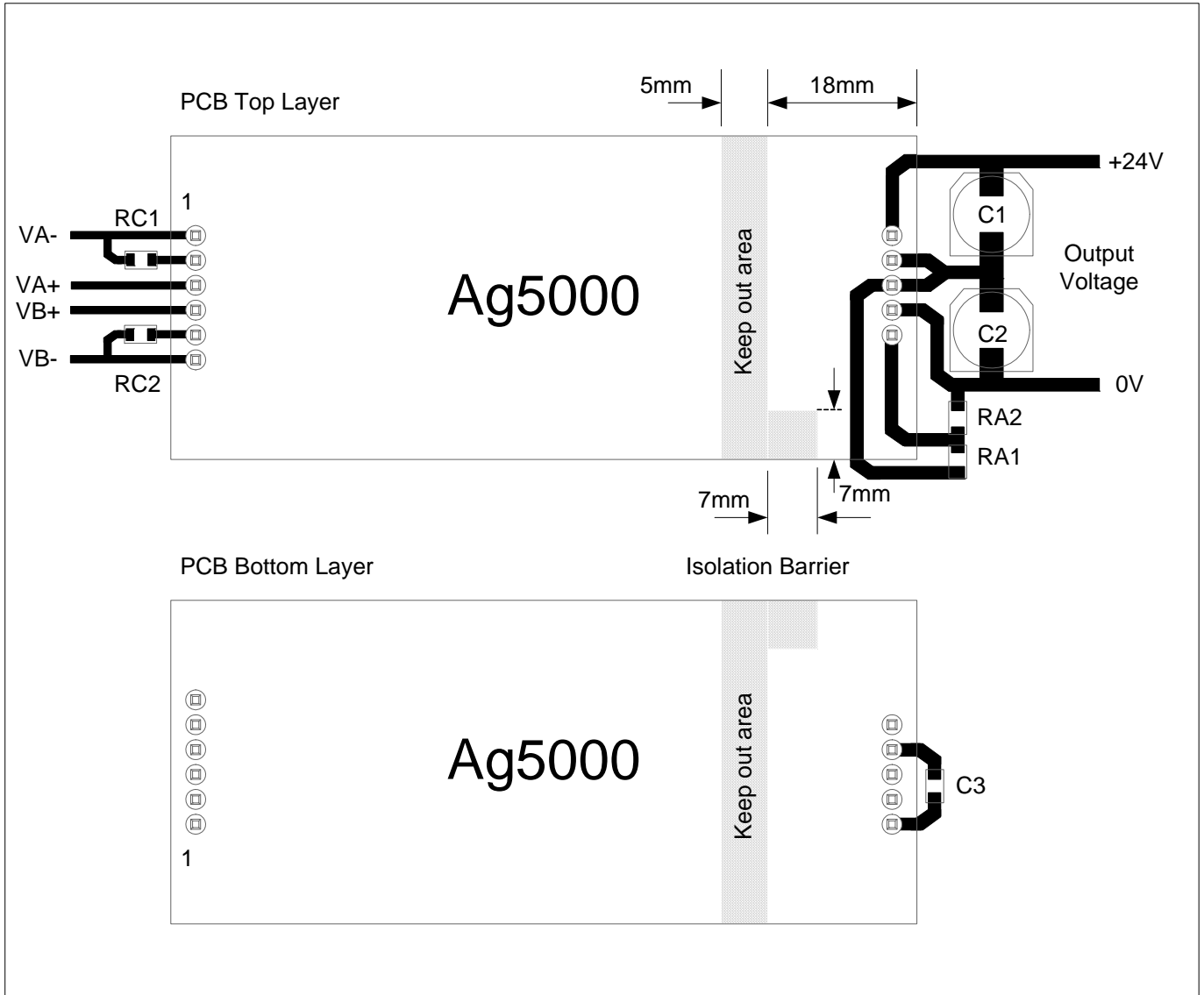

Ag5000 Output Configurations

Series Configuration 2

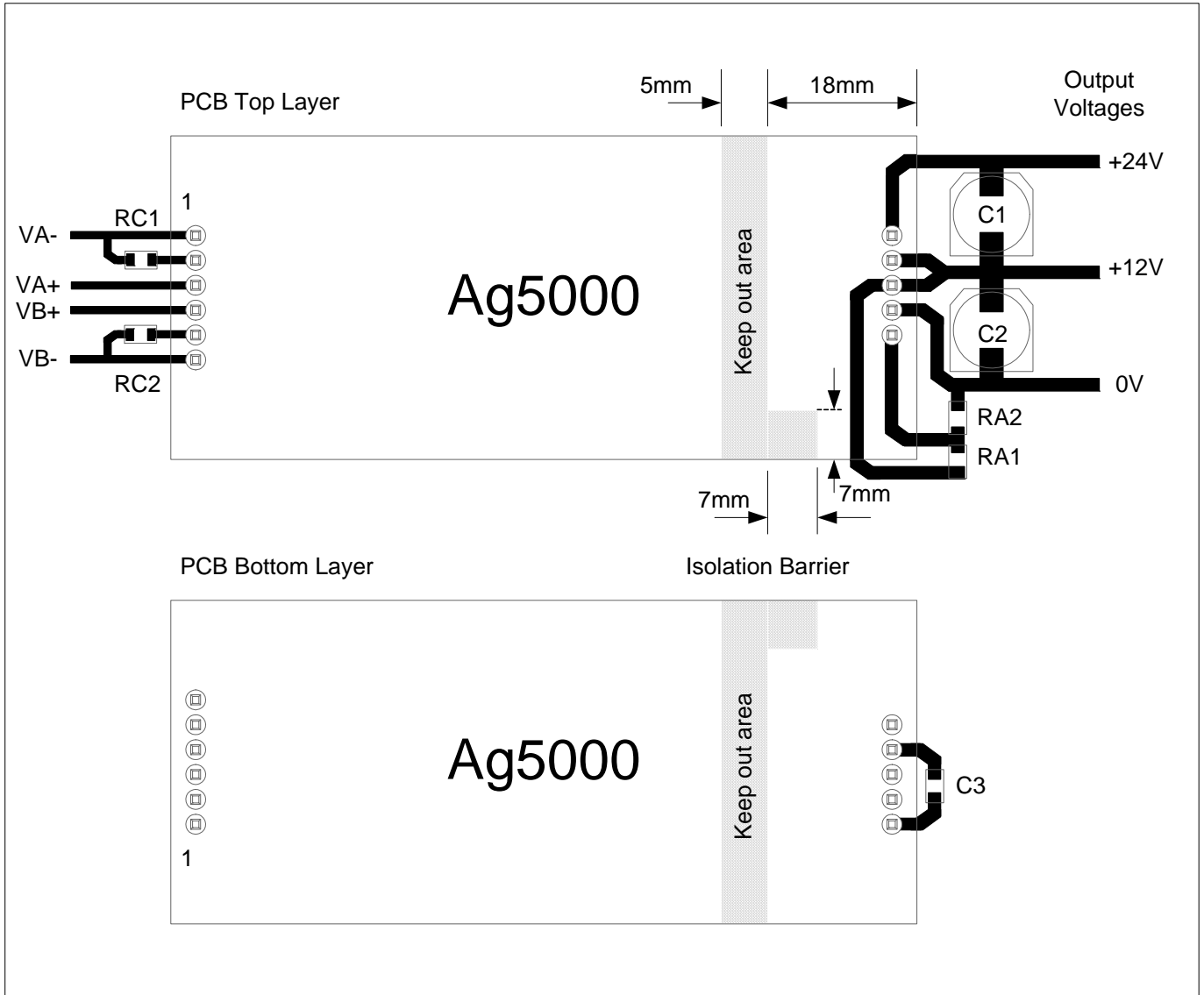

Ag5000 Output Configurations

Series Configuration 3

