

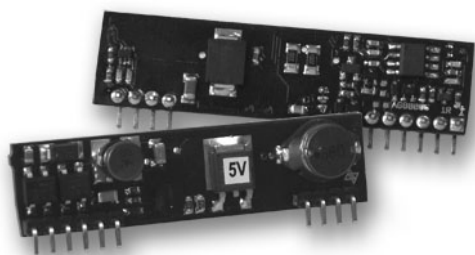

Ag8000

Power-Over-Ethernet Module



1 Features

- IEEE802.3af compliant
- Small package size - 56mm (L) x 14mm (H)
- Low output ripple and noise
- Input voltage range 36V to 60V
- Only one low cost external decoupling capacitor required
- Overload and short-circuit protection
- Adjustable Output - 3 product variants cover all voltages from 2.4V to 13V
- Thermal Cut Off
- High efficiency DC/DC converter
- Silvertel "design-in" assistance

2 Description

The Ag8000 series of modules are designed to extract power from a conventional twisted pair Category 5 Ethernet cable, conforming to the IEEE 802.3af Power-over-Ethernet (PoE) standard.

IEEE 802.3af allows for two power options for Category 5 cables and the Ag8000 series have two pairs of power inputs pins: - VA1&2 and VB1&2 to accommodate this, see Figure 1.

The Ag8000 signature and control circuit provides the PoE compatibility signature and power classification required by the Power Sourcing Equipment (PSE) before applying up to 15W power to the port. The Ag8000 is compatible with Class 0 to Class 3 equipment.

The high efficiency DC/DC converter operates over a wide input voltage range and provides a non-isolated regulated low ripple and low noise output. The DC/DC converter also has built-in output overload, output short-circuit and over-temperature protection.

Table of Contents

1	Features	1
2	Description.....	1
3	Ag8000 Product Selector	3
4	Pin Description	4
5	Functional Description	5
5.1	Inputs.....	5
5.2	PD Signature	5
5.3	Isolation	5
5.4	Power Classification	7
5.5	DC/DC Converter	7
5.6	Grounding.....	8
5.7	Output Adjustment.....	8
5.8	Typical Connections	10
6	Typical Application.....	11
7	Typical Recommendations	12
8	Operating Temperature Range	12
9	Protection	14
10	Electrical Characteristics.....	15
10.1	Absolute Maximum Ratings ¹	15
10.2	Recommended Operating Conditions.....	15
10.3	DC Electrical Characteristics	15
11	Package	16
11.1	Ag8000-S	16

2.1 Table of Figures

Figure 1:	Block Diagram	3
Figure 2:	Ag8000-S SIL Package Format	3
Figure 3:	Typical System Diagram.....	5
Figure 4:	Class Programming Option.....	7
Figure 5:	Output Adjustment	8
Figure 6:	Typical Connection Diagram.....	10
Figure 7:	Typical Application.....	11
Figure 8:	Typical Layout.....	12
Figure 9:	Power Plane Heatsink for Ag8000 (-S or -D).....	13
Figure 10:	Ag8003 Operating Profile	14
Figure 11:	Ag8005 Operating Profile	14
Figure 12:	Ag8012 Operating Profile	14

3 Ag8000 Product Selector

Part Number†	Nominal Output Voltage	Maximum Output Power *	Marking	Package
Ag8012-S	12.0V	12 Watts	12	SIL
Ag8005-S	5.0V	6 Watts	5	SIL
Ag8003-S	3.3V	5 Watts	3	SIL

*At 25°C with $V_{IN} = 48V$

† All versions of the Ag8000 fully meet the requirements of the RoHS directive 2002/95/EC on the restriction of hazardous substances in electronic equipment.

Table 1: Ordering Information

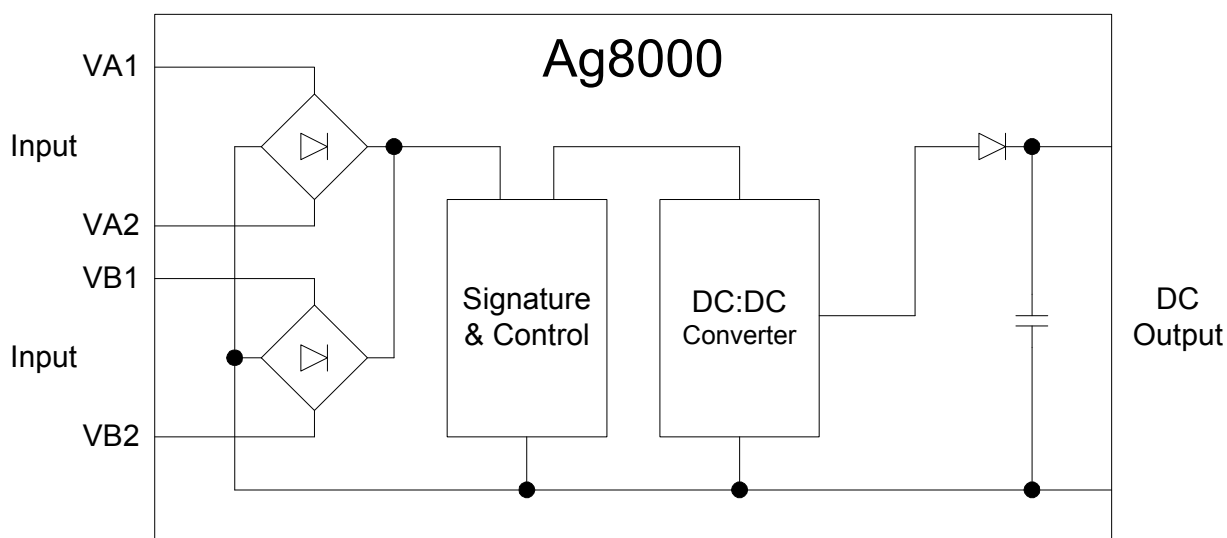

Figure 1: Block Diagram

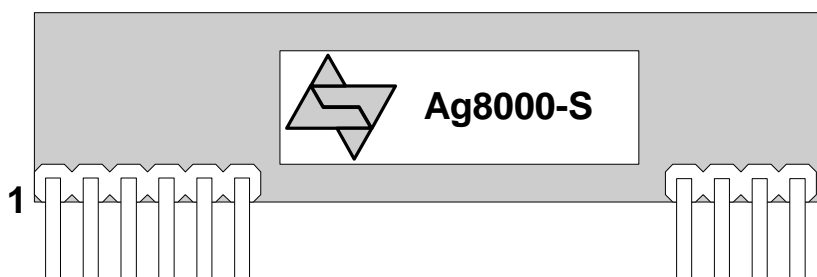

Figure 2: Ag8000-S SIL Package Format

4 Pin Description

Pin #	Name	Description
1	VA1	RX Input (1). This input pin is used in conjunction with VA2 and connects to the centre tap of the transformer connected to pins 1 & 2 of the RJ45 connector (RX) - it is not polarity sensitive.
2	VA2	TX Input (2). This input pin is used in conjunction with VA1 and connects to the centre tap of the transformer connected to pins 3 & 6 of the RJ45 connector (TX) - it is not polarity sensitive.
3	VB1	Direct Input (1). This input pin is used in conjunction with VB2 and connects to pin 4 & 5 of the RJ45 connector.
4	VB2	Direct Input (2). This input pin is used in conjunction with VB1 and connects to pin 7 & 8 of the RJ45 connector.
5	CP1	Class Programming (1). Connect an external resistor to CP2 will change the current class of the module. With no resistor fitted the Ag8000 will default to Class 0.
6	CP2	Class Programming (2). Connect an external resistor to CP1 will change the current class of the module. With no resistor fitted the Ag8000 will default to Class 0.
7	-VDC	Negative DC Output. This pin provides the regulated output from the DC/DC converter.
8	+VDC	Positive DC Output. This pin provides the regulated output from the DC/DC converter.
9	ADJ	Output Adjust. The output voltage can be adjusted from its nominal value, by connecting an external resistor from this pin to either the +VDC pin or the -VDC pin.
10	IC	Internal Connection. Do not connect to this pin.

5 Functional Description

5.1 Inputs

The Ag8000 has two internal bridge rectifiers (see Figure 1: Block Diagram) connected to the VA1-VA2 and the VB1-VB2 inputs. This allows the Ag8000 to be compatible with equipment that use the different power options, see Figure 3: Typical System Diagram. It is important that the PSE does not apply power to the VA and VB outputs at the same time (Refer to IEEE802.3af for more information).

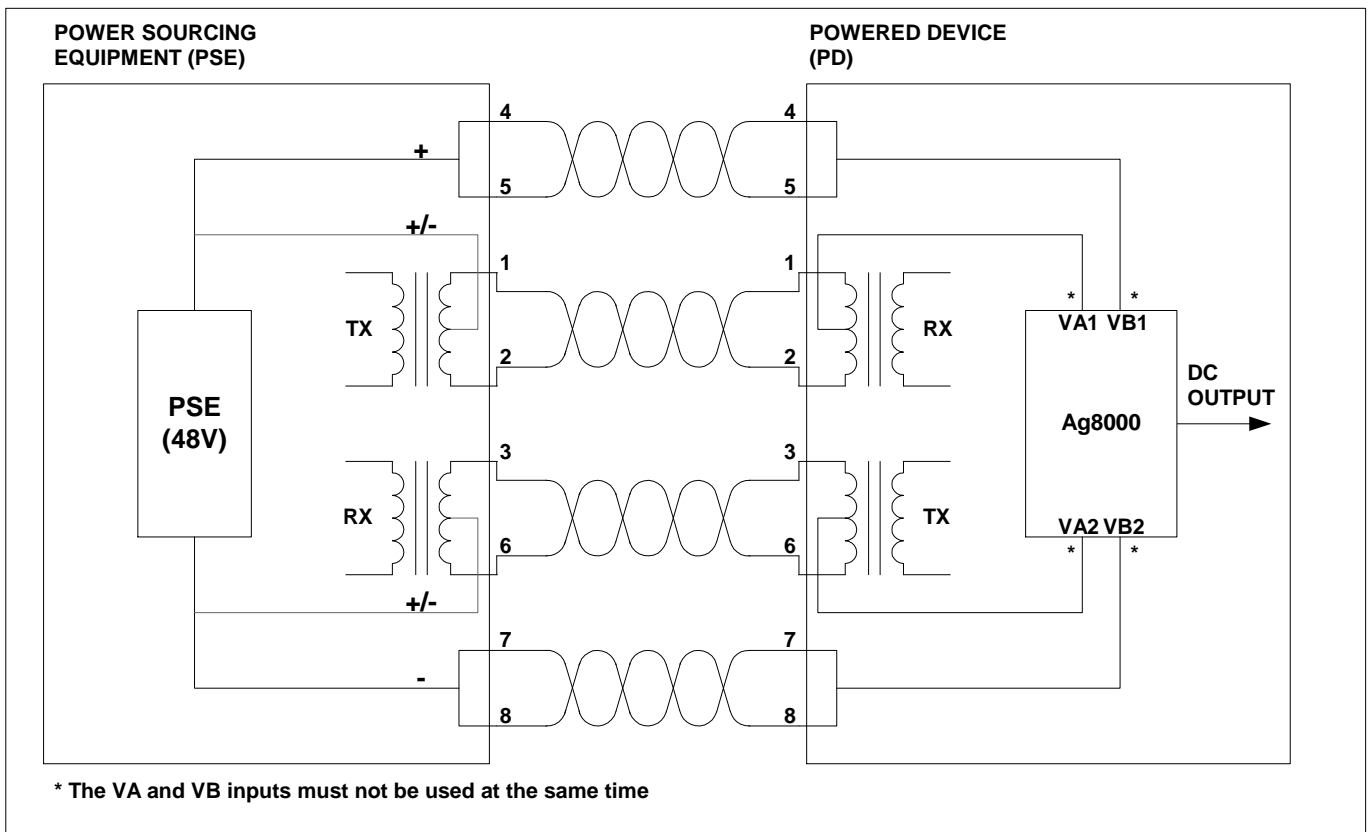

Figure 3: Typical System Diagram

5.2 PD Signature

When the Ag8000 is connected to the Cat 5e cable, it will automatically present a Powered Device (PD) signature to the Power Sourcing Equipment (PSE) or Midspan Equipment, when requested. The equipment will then recognise that a powered device is connected to that line and supply power.

5.3 Isolation

The Ag8000 series conforms to the IEEE 802.3af standard except for the 1500V isolation, which must be done externally. This is usually achieved without additional components, contact Silvertel for further details.

5.4 Power Classification

This is optional from the PSE and is used for power management. The Ag8000 allows the current class to be externally programmed by connecting a resistor between the CP1 and CP2 pins, see Figure 4: Class Programming Option. If no resistor is fitted the Ag8000 will default to Class 0, a full list of programming resistor values are shown in Table 2: Class Programming.

CLASS	Programming Resistance (Ohms)	Min Power (W)	Max Power (W)
0	Do not fit	0.44	12.95
1	698 \pm 1%	0.44	3.84
2	383 \pm 1%	3.84	6.49
3	249 \pm 1%	6.49	12.95
4	TBD	Reserved	Reserved

Table 2: Class Programming

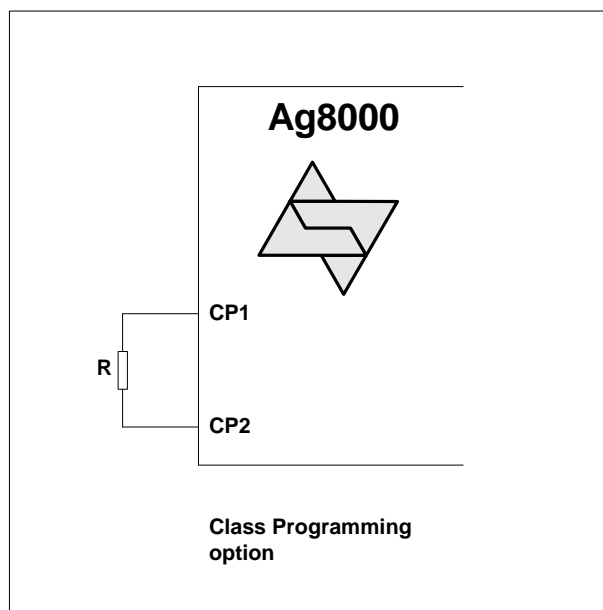

Figure 4: Class Programming Option

5.5 DC/DC Converter

The Ag8000's DC/DC converter provides a non-isolated regulated low ripple and low noise output, that has built-in overload and short-circuit output protection, as well a built-in thermal cut-off - see Table 1: Ordering Information for voltage and power ratings.

Because the Ag8000 series is non-isolated the +VDC output is connected to the positive input through a diode bridge.

5.6 Grounding

If the Ag8000 is supplied from a grounded source (e.g. a standard multi-channel PSE) it is important that the -VDC output is **NOT** connected to ground.

Connecting both input and output to ground will short circuit the input diode bridge, this prevents correct operation of the Ag8000.

5.7 Output Adjustment

The Ag8000 has an ADJ pin, which allows the output voltage to be increased or decreased from its nominal value.

Figure 5: Output Adjustment shows how the ADJ pin is connected: -

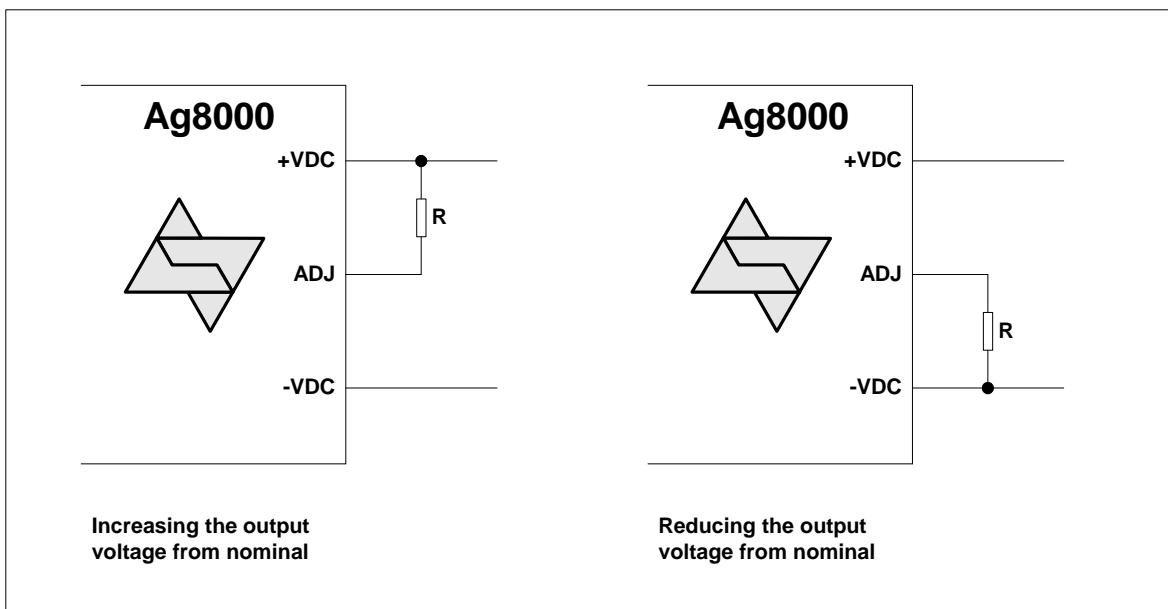

Figure 5: Output Adjustment

Reducing the output voltage, connect R between ADJ and -VDC			
Value of R	Ag8003 output	Ag8005 output	Ag8012 output
Open Circuit	3.3V	5.0V	12.0V
15K	3.0V	4.3V	9.0V
0 Ohms	2.5V	2.5V	7.5V
Increasing the output voltage, connect R between ADJ and +VDC			
Value of R	Ag8003 output	Ag8005 output	Ag8012 output
Open Circuit	3.3V	5.0V	12.0V
15K	3.5V	5.3V	12.5V
0 Ohms	4.5V	7.5V	13.0V

Table 3: Output Adjustment Resistor (R) Value

*Note: the results in Table 3 are under minimum load conditions

5.8 Typical Connections

The Ag8000 only requires one external component as shown in Figure 6: Typical Connection Diagram, a minimum of 470 μ F is recommended.

The value of C1 will be related to the maximum load step change that the output needs to drive. For example, in an application where the output needs to cope with a 1.8 Amp load step change, a minimum of 1000 μ F should be used. This can be a standard low cost electrolytic and does not need to be a low ESR type.

Figure 6 shows a 16V capacitor that would cover all product variants up to and including the Ag8012, see Table 1: Ordering Information.

The Class programming and the Output Adjust inputs are optional and are provided to give great flexibility to the Ag8000 product range. Further information on using these inputs can be found in sections Power Classification and Output Adjustment.

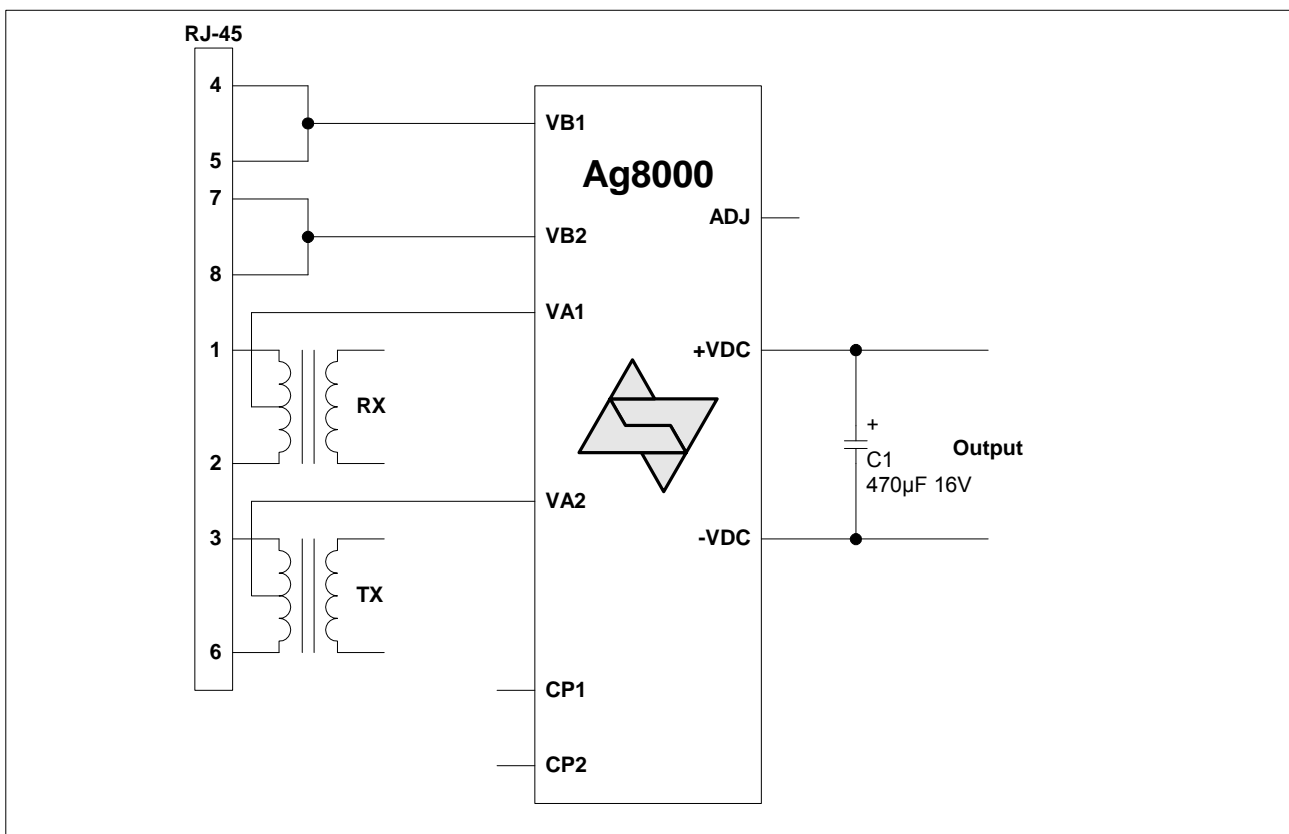

Figure 6: Typical Connection Diagram

6 Typical Application

The Ag8000 can be used in numerous applications. In the example shown in Figure 7: Typical Application, the data outputs from the switch are connected to the inputs of a midspan. The midspan will then add power (to the data) on each output that supports Power over Ethernet (PoE).

In this example port 1 is connected to an ethernet camera and port 2 is connected to a wireless access point, both of these devices have a built-in Ag8000. When the midspan is switched on (or when the device is connected), the midspan will check each output for a PoE signature. On ports 1 and 2 the Ag8000 will identify themselves as PoE enabled devices and the midspan will supply both data and power to these peripherals.

The other ports (shown in this example) will not have a PoE signature and the midspan will only pass the data through to these peripherals. The midspan will continuously monitor each output to see if a PoE enabled device has been added or removed.

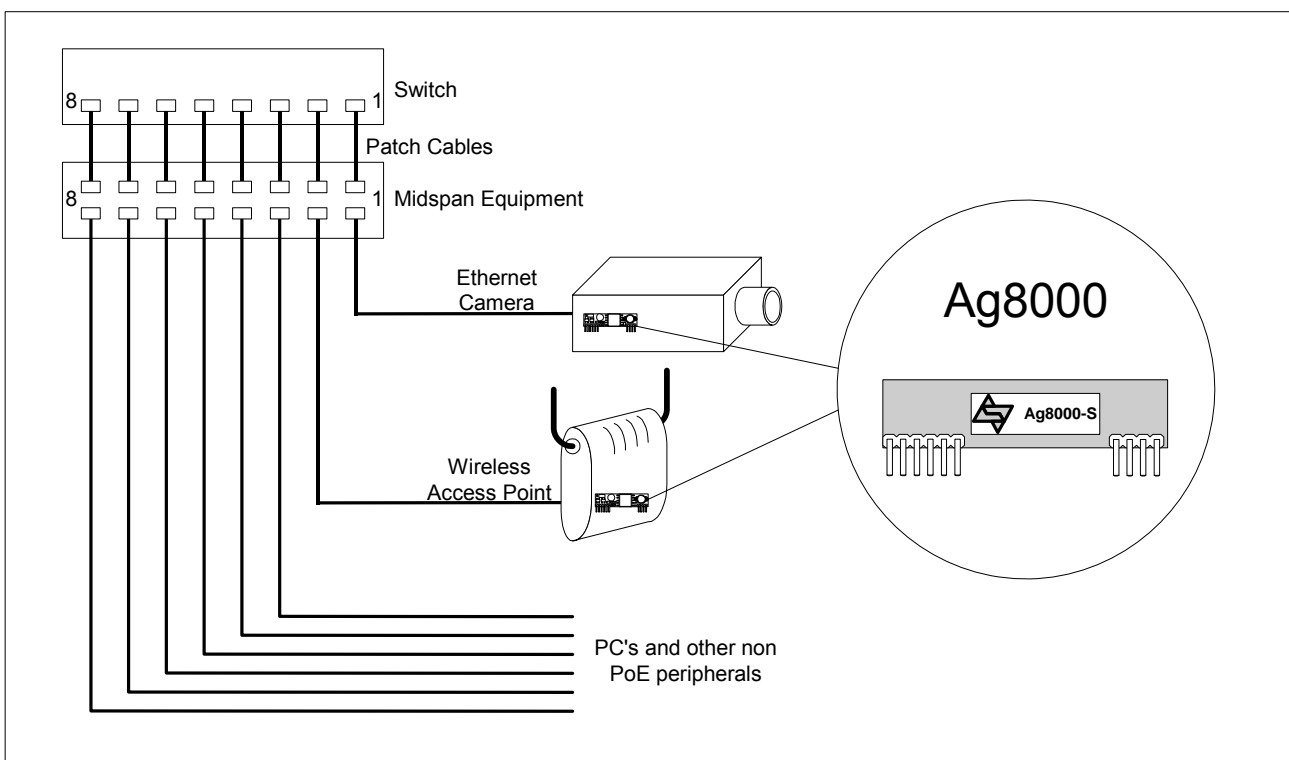

Figure 7: Typical Application

7 Typical Recommendations

Figure 8: Typical Layout gives an example of the tracking needed for the Ag8000. R1, R2 and R3 are optional components, but C1 needs to be positioned close to the output pins of the Ag8000 as possible to minimise the current loop. The thermal performance of the Ag8000 can be improved by increasing the surface area of the output tracks (+VDC and -VDC) this is not applicable if the Ag8000 is in a socket.

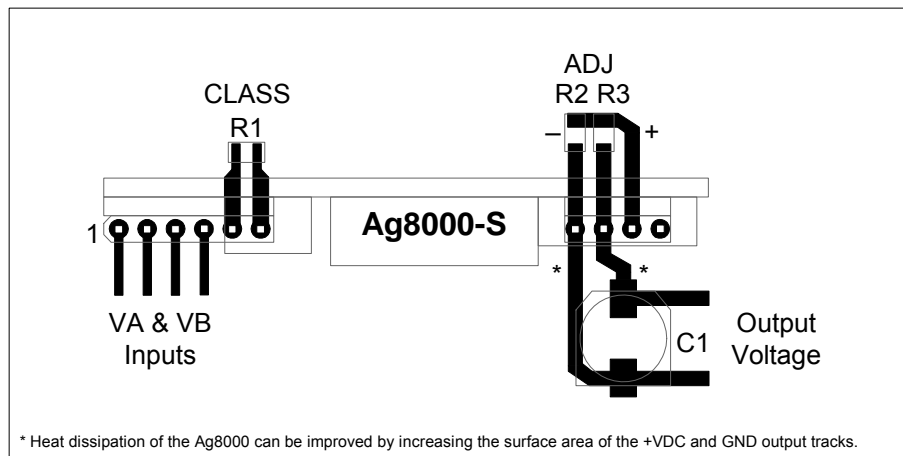

Figure 8: Typical Layout

8 Operating Temperature Range

Because the Ag8000 is a power component, it will generate heat, so it is important that this be taken into consideration at the design stage.

The heart of the Ag8000 is a DC/DC converter, which like any other power supply will generate heat. The amount of heat generated by the module will depend on the load it is required to drive and the input voltage supplied by the PSE. The information shown within this section of datasheet is referenced to a nominal 48Vdc input voltage supplied by the PSE.

The Ag8000 has a maximum ambient operating temperature of 70°C see Figure 10, Figure 11 & Figure 12. These results are in still air without any heatsinking, the performance of the Ag8000 can be improved by forcing the airflow over the part or by using a heatsink (see the Ag8000 application note on heatsinking for more information).

The output stage of the Ag8000 has a built-in thermal protection circuit, to prevent the module from being damaged if operated beyond its power / temperature specification.

Because each application is different it is impossible to give fixed and absolute thermal recommendations. However it is important that any enclosure used has sufficient ventilation for the Ag8000 and a direct airflow if possible.

One simple method for drawing some of the heat away from the Ag8000 is shown in Figure 9. Power planes connected to the +VDC and GND pins of the Ag8000 can be used to draw heat away from the DC/DC converter via the output pins.

These power planes must be on the outer layers of the PCB and the Ag8000 must not be fitted into a socket (this example is suitable for both -S and -D variants).

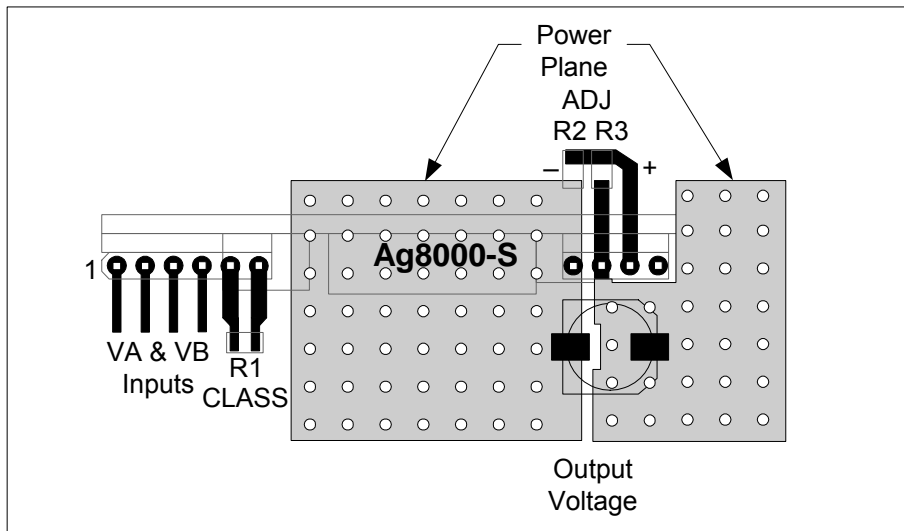

Figure 9: Power Plane Heatsink for Ag8000 (-S or -D)

Figure 10, Figure 11 & Figure 12 show the maximum ambient temperature under different load conditions. These figure have been recorded in a sealed enclosure (in still air) using a heater element to elevate the ambient temperature (within the enclosure).

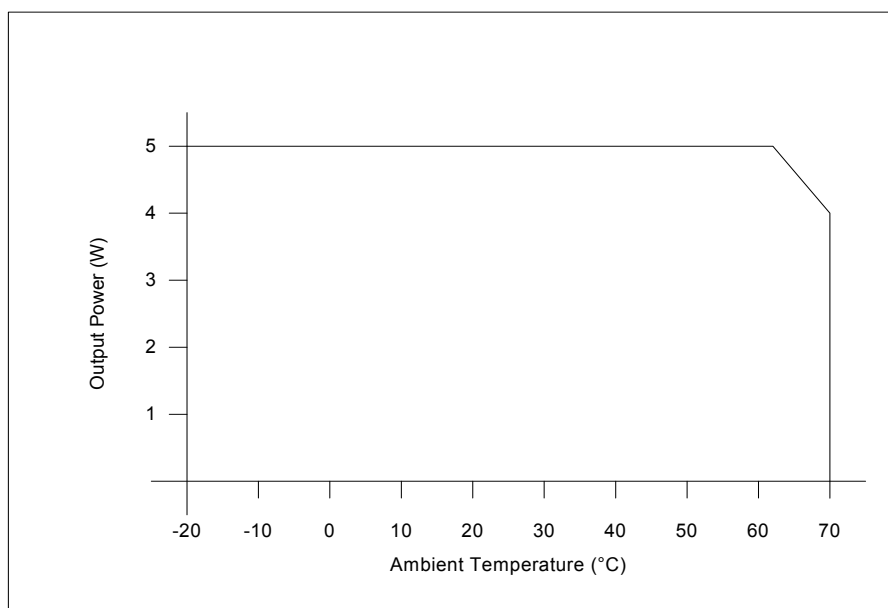

Figure 10: Ag8003 Operating Profile

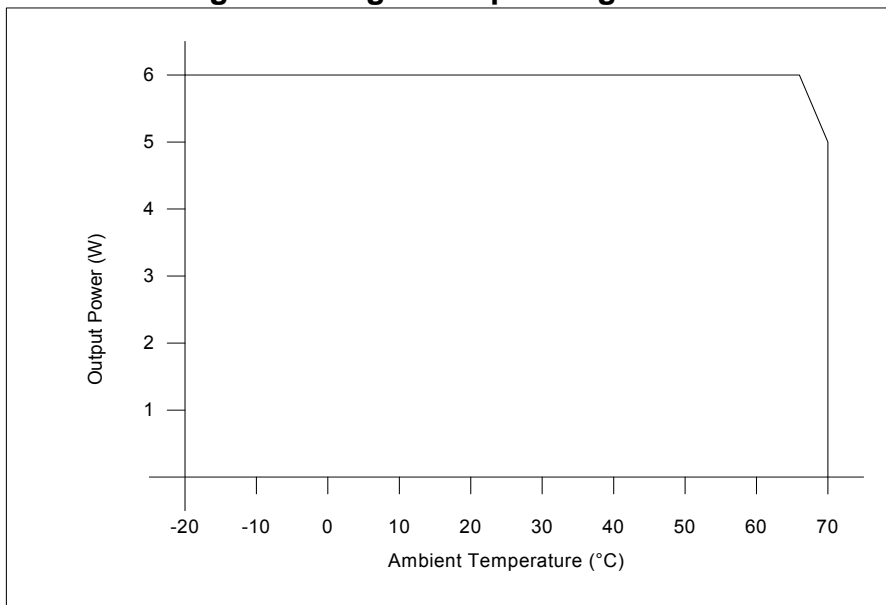

Figure 11: Ag8005 Operating Profile

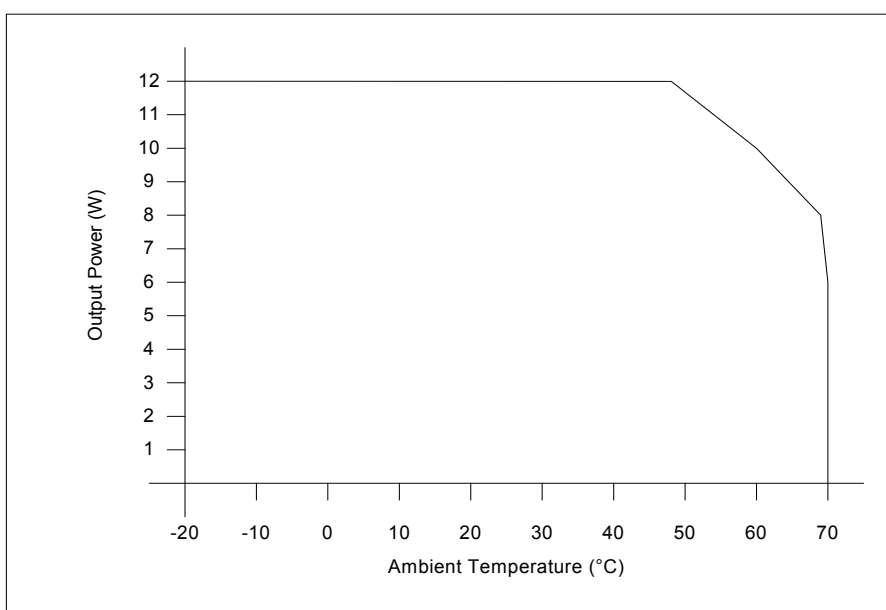

Figure 12: Ag8012 Operating Profile

9 Protection

The Ag8000 must be protected from over-voltages exceeding the 80V maximum rated surge input voltage. An inexpensive but effective solution can be achieved by connect Tranzorb diodes across each of the inputs; see Apps Note "ANX-POE-Protection".

10 Electrical Characteristics

10.1 Absolute Maximum Ratings¹

	Parameter	Symbol	Min	Max	Units
1	DC Supply Voltage	V_{CC}	-0.3	60	V
2	DC Supply Voltage Surge for 1ms	V_{SURGE}	-0.6	80	V
3	Storage Temperature	T_S	-40	+100	°C

Note 1: Exceeding the above ratings may cause permanent damage to the product. Functional operation under these conditions is not implied. Maximum ratings assume free airflow.

10.2 Recommended Operating Conditions

	Parameter	Symbol	Min	Typ	Max	Units
1	Input Supply Voltage	V_{IN}	36	48	57	V
2	Under Voltage Lockout	V_{LOCK}	30		36	V
3	Operating Temperature	T_{OP}	-20	25	70 ¹	Ta / °C

Note 1: See Section Operating Temperature Range

10.3 DC Electrical Characteristics

	DC Characteristic	Sym	Min	Typ ¹	Max	Units	Test Comments
1	Output Voltage	V_{OUT}	2.5	3.3	4.5	V	Ag8003
			2.5	5	7.5	V	Ag8005
			7.5	12	13	V	Ag8012
2	Output Current ($V_{IN} = 48V$)	I_{OUT}			1.5	A	Ag8003
					1.2	A	Ag8005
					1	A	Ag8012
3	Line Regulation	V_{LINE}		0.1		%	
4	Load Regulation	V_{LOAD}		3.5		%	
5	Output Ripple	V_{RP}		100		mVp-p	@ Max load ²
6	Output Ripple and Spikes	V_{SPK}		200		mVp-p	@ Max load ²
7	Minimum Load	R_{LOAD}	100			mA	for specified regulation ³
8	Short-Circuit Duration ⁴	T_{SC}			∞	sec	
9	Efficiency	EFF		74		%	Ag8012 @ 50% Load
10	Temperature Coefficient	TC		0.05		%	Per °C

Note 1: Typical figures are at 25°C with a nominal 48V supply and are for design aid only. Not Guaranteed

2: The output ripple and spikes can be reduced with an external filter, see application note.

3: Can be used with no load at reduced voltage regulation.

4: Continuous short circuit duration is applicable at 25°C ambient temperature in free air. At higher temperatures or with restricted airflow (e.g. in a sealed enclosure) the duration will need to be limited to avoid overheating.

11 Package

11.1 Ag8000-S

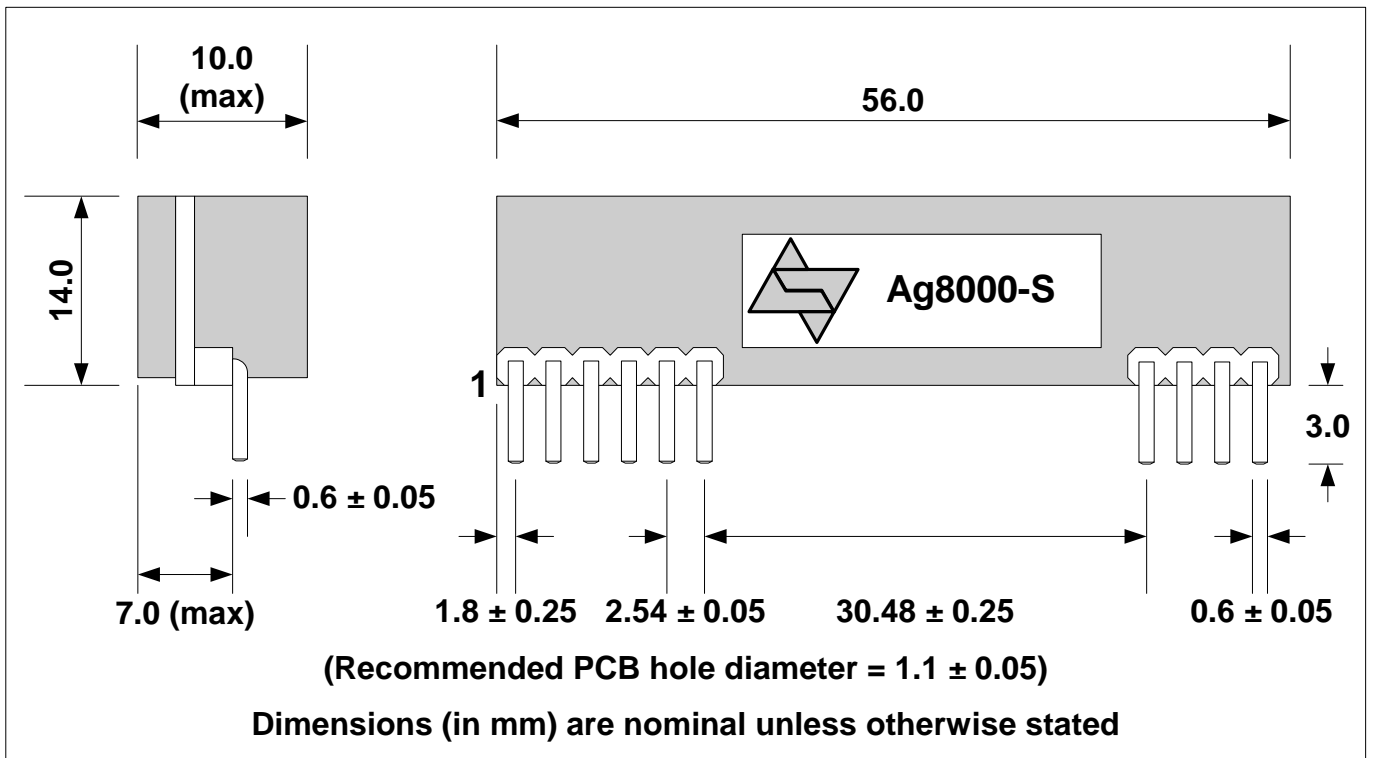

Information published in this datasheet is believed to be correct and accurate. Silver Telecom assumes no liability for errors which may occur or for liability otherwise arising out of use of this information or infringement of patents which may occur as a result of such use. No license is granted by this document under patents owned by Silver Telecom or licensed from third parties by Silver Telecom. The products, their specification and information appearing in this document are subject to change by Silver Telecom without notice.